



NXL-AVI

CONTACT INPUT PANEL

OVERVIEW

The NexLight® NXL-AVI is a Contact Input Accessory Panel commonly used for integration of A/V systems with the NexLight Lighting Control System. The small enclosure can easily be mounted adjacent to the system providing contact closures. Contact Closures may be momentary or maintained allowing flexibility in achieving the desired sequence of operation. The NXL-AVI requires no transformer for control power, the only control power required is supplied by the NexLight 2-Wire Data Bus to provide up to 8 Contact Inputs. This panel includes a Surface Mount NEMA/Type 1 Enclosure with a flat cover secured by screws.

SPECIFICATIONS

Physical

NEMA/Type:	1
Mounting:	Surface Mount
Operating Temperature:	14° to 113°F (-10°C to 45°C)

Electrical (Control Wiring)

Input Signal:	24VAC, Class II
---------------	-----------------

FEATURES

- **(8) Contact Inputs that accept "Dry" Contact Closures**
- **Use with R Series, D Series, or a Custom Panel**
- **Simple Integration of 3rd Party Systems and Devices into the NexLight System**
- **Maintained Closures control Individual and Group Addresses**
- **Momentary Closures control Scene Addresses**

ADDITIONAL PANELS

**See individual accessory specification sheet for more information

NXL-R Series	NexLight R Series Relay Panels
NXL-D Series	NexLight D Series Dimming Panels
NXL-RC Series	NexLight RC Series Room Control Panels
NXL-OPC:	Outdoor Photocell Integration Panel, Remote Mounting (8"H x 8"W x 4"D)
NXL-00P5:	Dimming Expansion, (8) Channels of 0-10 Dimming (100mA Sinking per Channel) (8"H x 8"W x 4"D)
NXL-BMS:	BACnet Protocol Conversion Panel for Building Management System (BMS) Integration (12"H x 12"W x 6"D)
NXL-AMP:	Amplifier Panel for NexLight Data Bus, Supports an additional 485 mA of system devices (12"H x 12"W x 6"D)

NXL-AVI

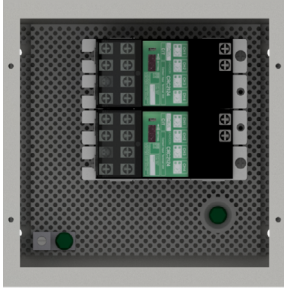

Included Components

- 2 CRC2124 Contact Input Modules (4 Inputs Each)
- 1 PA-80-1 Panel Assembly

Physical Specifications

NEMA/Type:	1
Mounting:	Surface Mount
Dimensions:	8.00"H x 8.00"W x 4.00"D
Weight:	6 lbs 9.6 oz
Addresses Available:	N/A (Requires Main Panel)
Addresses Used:	0
mA Available:	N/A (Requires Main Panel)
mA Draw:	12 mA
Operating Temperature:	14° to 113°F (-10°C to 45°C)

WIRING DIAGRAM

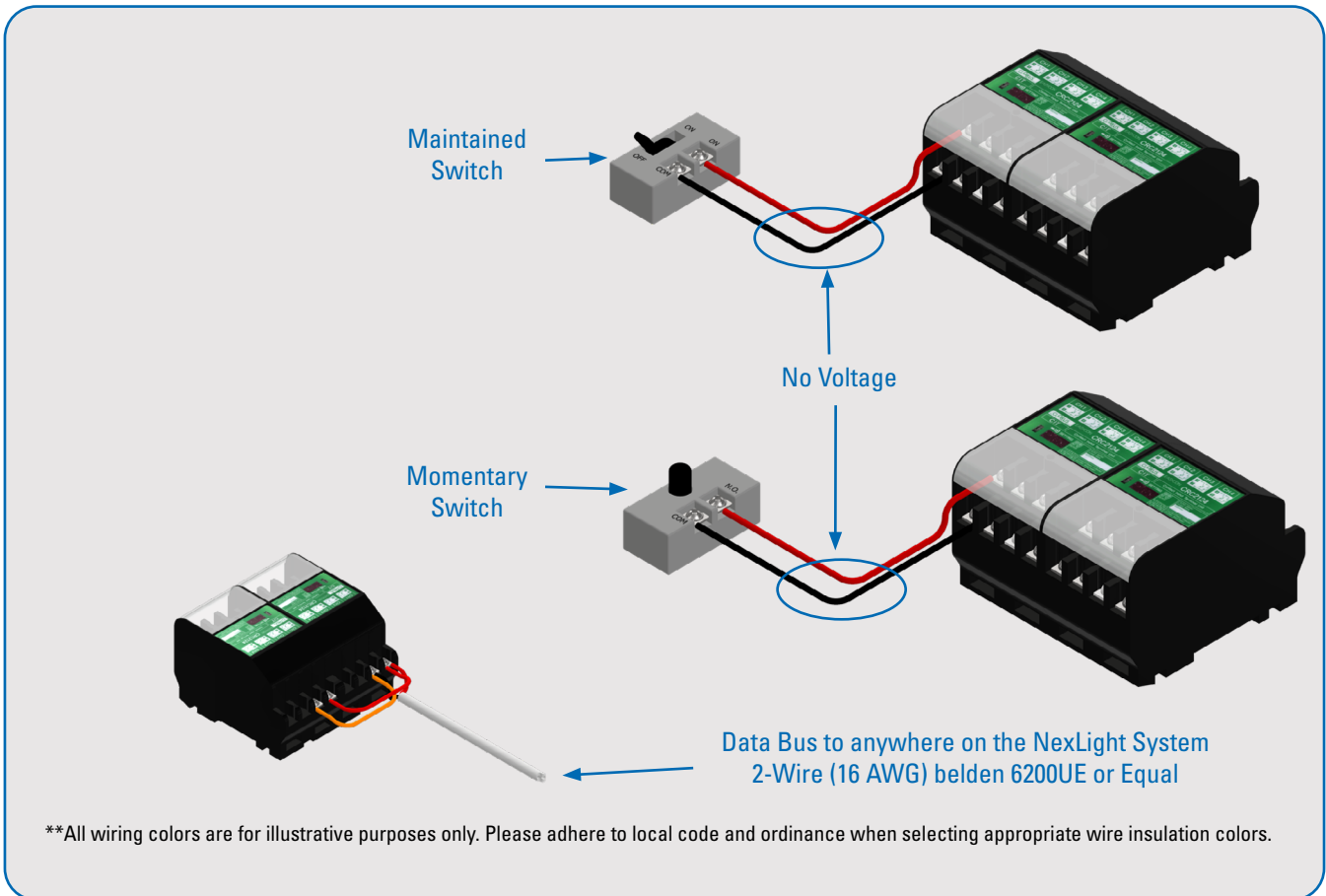

NXL-AVI

CONTACT INPUT PANEL

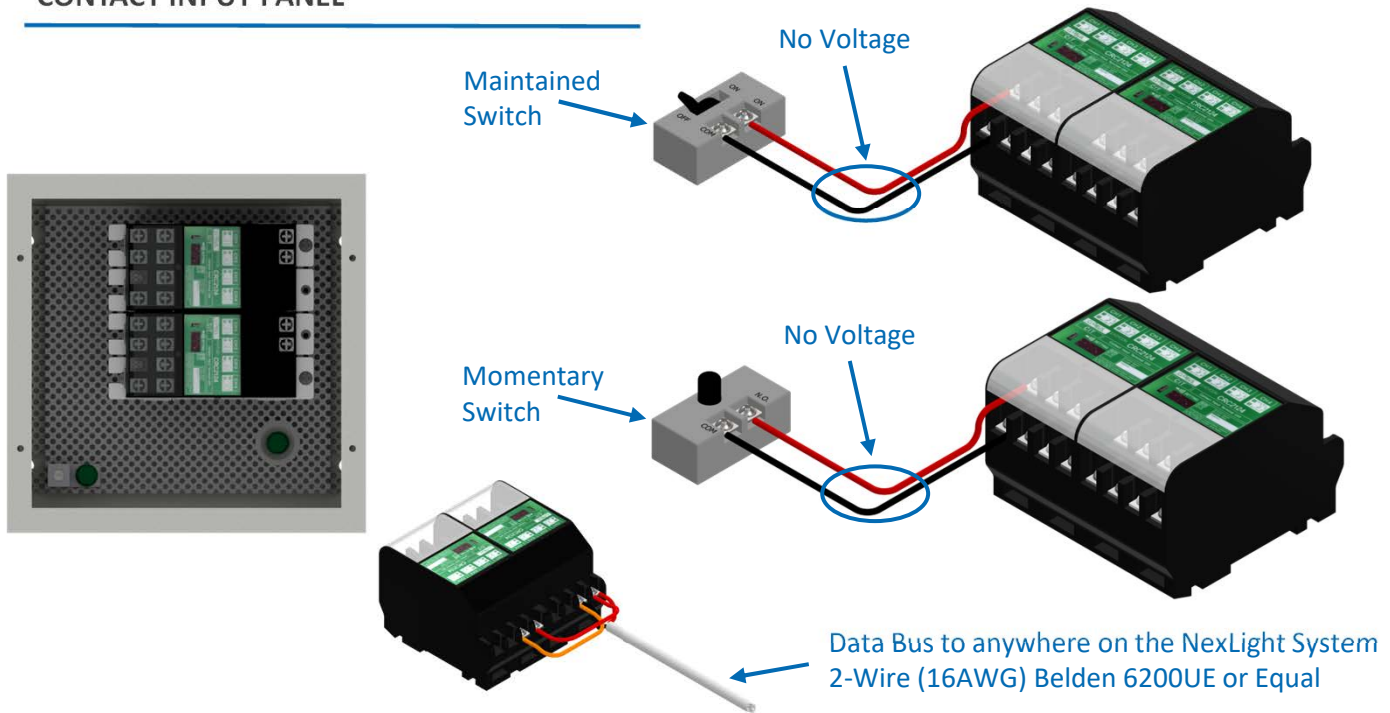

APPLICATION OVERVIEW

The NXL-AVI is a Contact Input Accessory Panel commonly used for integration of A/V systems with the NexLight Lighting Control System. The small enclosure can easily be mounted adjacent to the system providing contact closures. Contact Closures may be momentary or maintained allowing flexibility in achieving the desired sequence of operation. The NXL-AVI requires no transformer for control power, the only control power required is supplied by the NexLight 2-Wire Data Bus to provide up to 8 Contact Inputs.

APPLICATION HIGHLIGHTS

- (8) Contact Inputs that accept “Dry” Contact Closures.
- Use with R Series, D Series or a Custom Panel.
- Simple integration of 3rd party systems and devices into the NexLight System.

TYPICAL DATA BUS CONNECTIONS

